

* FOR BIDDING PURPOSE ONLY *

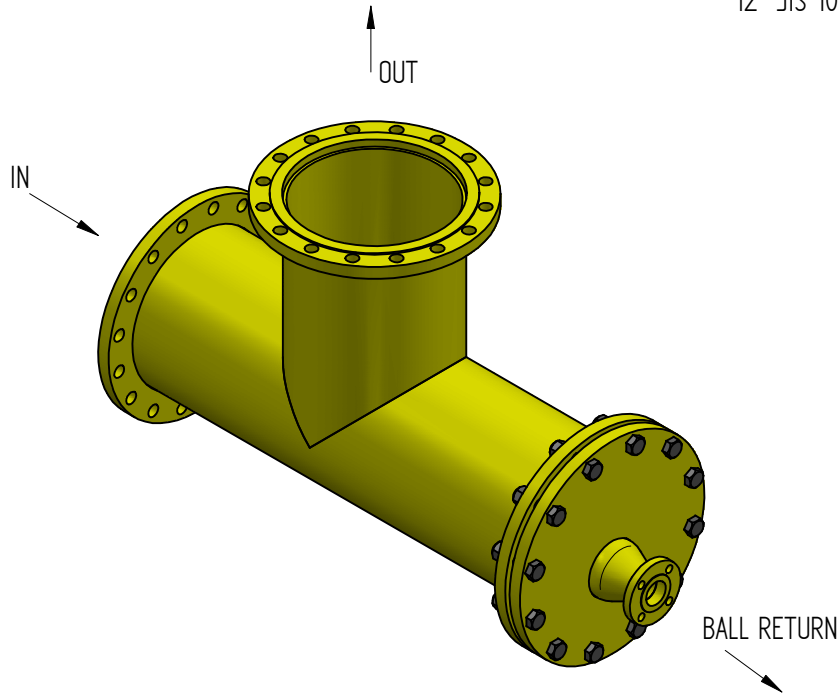
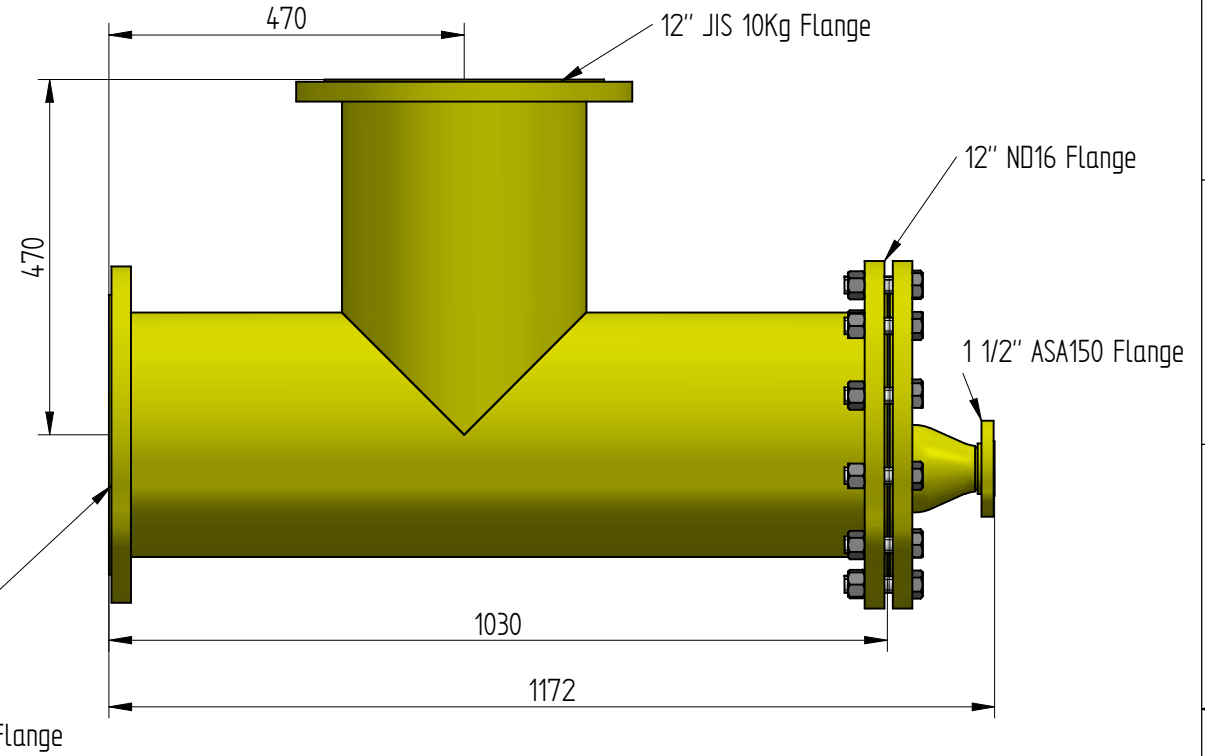
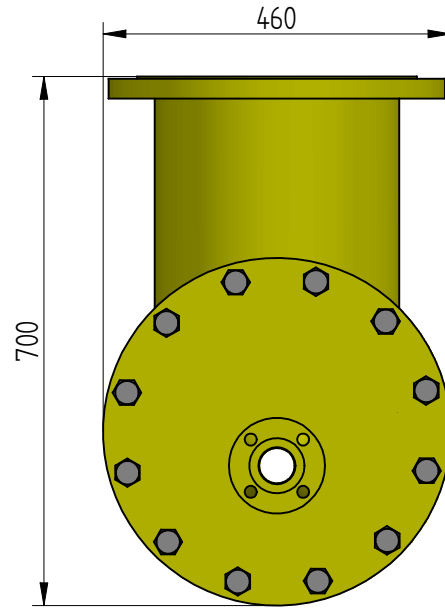

Linear Tolerance: ± 0.3		Name		Date			
.X ± 0.2	.XX ± 0.02	Drawn	igor	03/05/2011	System:		
Angle Tolerance: ± 1/2°		Checked		03/05/2011	12" AT		
Surface Roughness: 63		EMPTY WEIGHT Kg		180 kg	Title:		
Blunt Sharp Edges: 0.1, 0.3		WORKING WEIGHT Kg		270 kg	12" Angular Type Ball Trap JIS10Kg Flanges		
FIRST ANGLE PROJECTION		Scale:	Size:	A2	Draft no.:	201003-421-1	Rev: 1
All Dimensions Befor Coating		UNLESS OTHERWISE SPECIFIED ALL DIMENSIONS ARE IN MILLIMETERS		100-421	מק"ט פריט:	Sheet: 1	Sheets: 1