

CRYSTOLITE FILTER SIDE VIEW

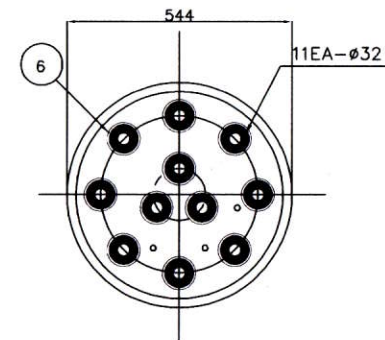

SECTION: A-A" 5

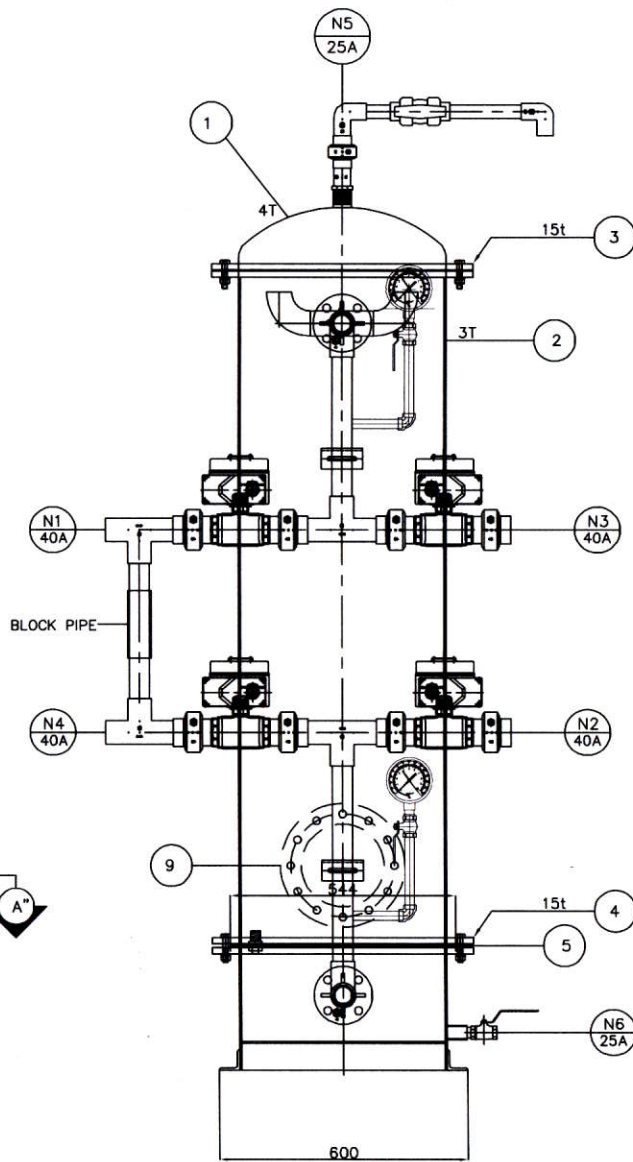
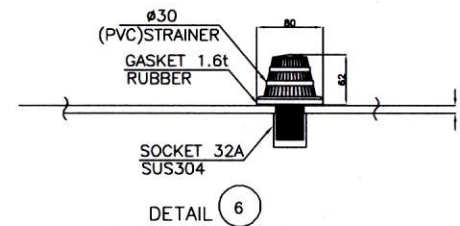

9	SIDE HOLE	200A	SUS304	1	
8	CRYSTOLITE MEDIA	196L			
7	GRAVEL	28L			
6	STRAINER	32ø	P.P	11	
5	STAINER PLATE	ø544X4T	SUS304	1	
4	BOTTOM FLANGE	ø500x15t	SUS304	1	
3	TOP FLANGE	ø500x15t	SUS304	1	
2	BODY SHELL	ø650xH1394X2t	SUS304	1	
1	DOME	ø600X4T	SUS304	1	
N6	MANUAL DRAIN	25A	SUS304	1	
N5	AIR VENT	25A	CPVC	1	
N4	CITY WATER INLET	40A	CPVC	1	
N3	BACKWASH DRAIN	40A	CPVC	1	
N2	OUTLET	40A	CPVC	1	
N1	INLET	40A	CPVC	1	
NO	DESCRIPTION	SIZE	MAT'L	Q'TY	REMARK

CUSTOMER				
SUPPLIER	CQM-JAPAN. CO.,LTD			
TITLE	CRYSTOLITE MEDIA FILTER G.A DWG			
MODEL	CR50-4M3/HR			
DWG. NO.	DS-CR-5001	REV. NO.	0	